

ISOE
SCALE 1:1.5

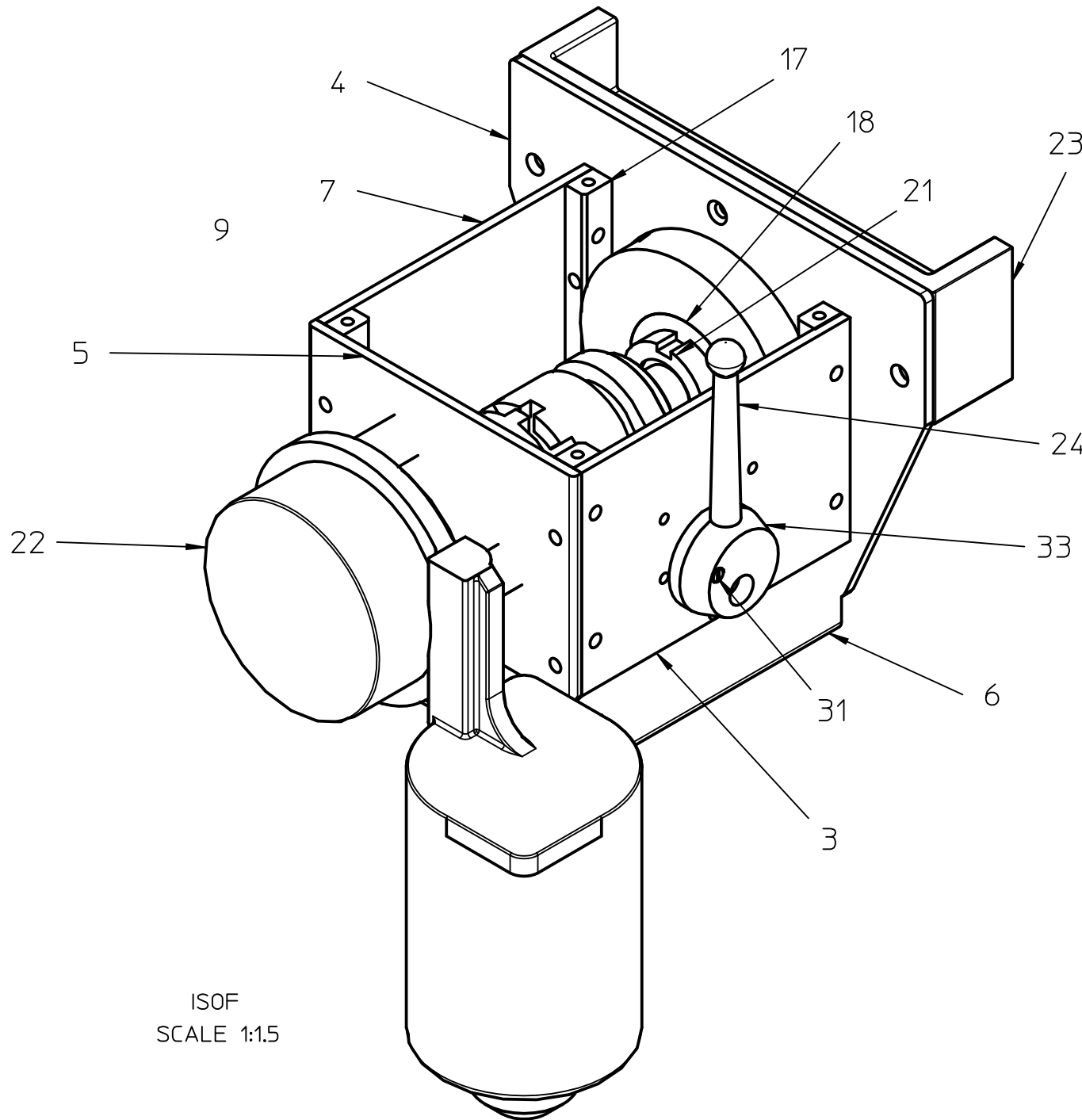

ISOF
SCALE 1:1.5

Pos	Part No.	Part Name
1		MidCover
2		ActArmGuide.1
3		SideFrame
4		BackFrame
5		FrontFrame
6		BottomCover
7		BkSideFrame
8		ActArmGuide
9		ClutchCover
10		stand
11		stand.1
12		stand.1.1
13		stand.1.1.1
14		CornerPost
15		CornerPost.1
16		CornerPost.1.1
17		CornerPost.1.1.1
18		Bearing
19		Key
20		spindle
21		nut
22		Motor
23		casting
24		OpHandle
25		ClutchKeyway
26		Clutch
27		DrivePlate
28		Ball
29		DriveRegister
30		ClutchActArm
31		Screw
32		Spring
33		OpHandleBase
34		DriveNut
35		TopCover

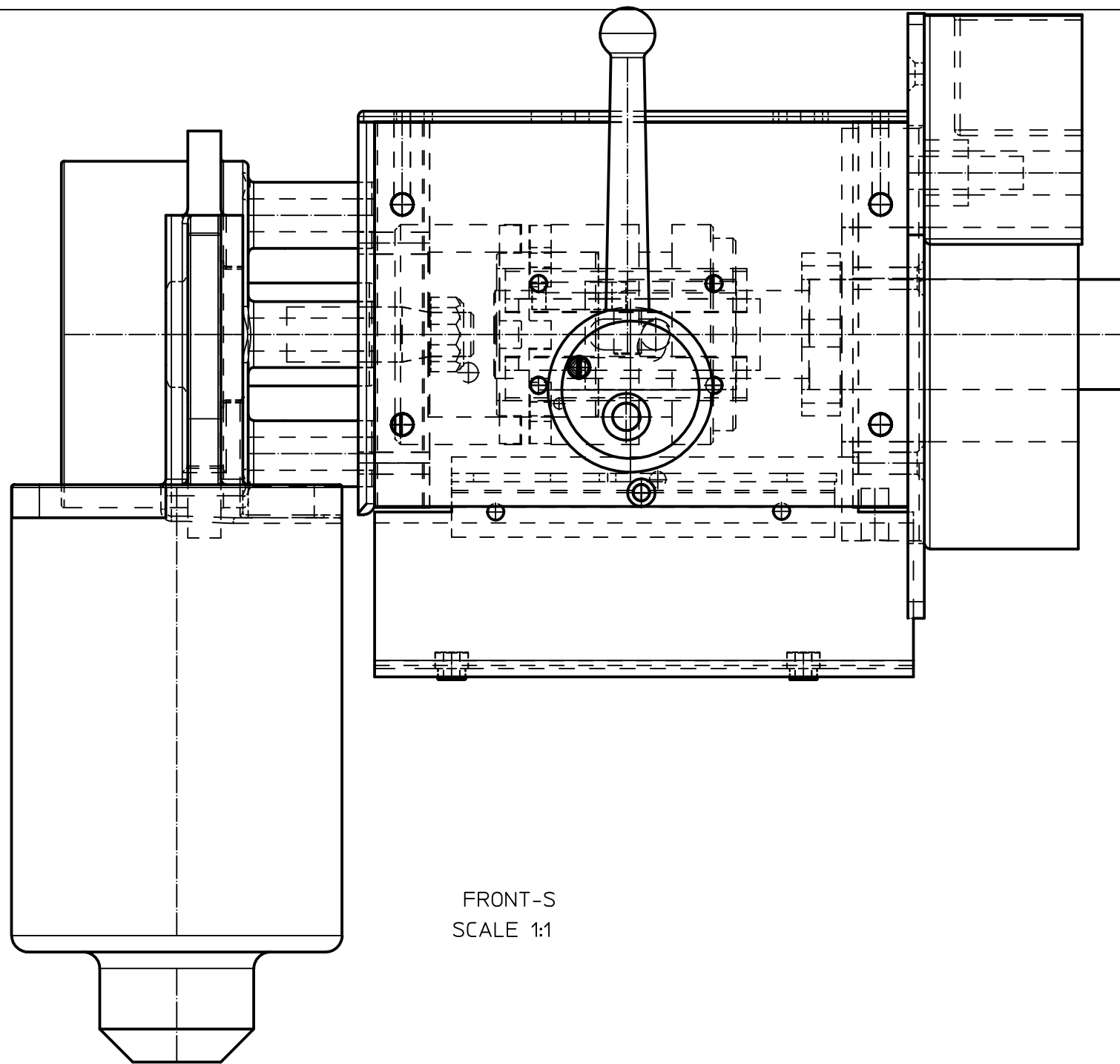

FRONT-S
SCALE 1:1

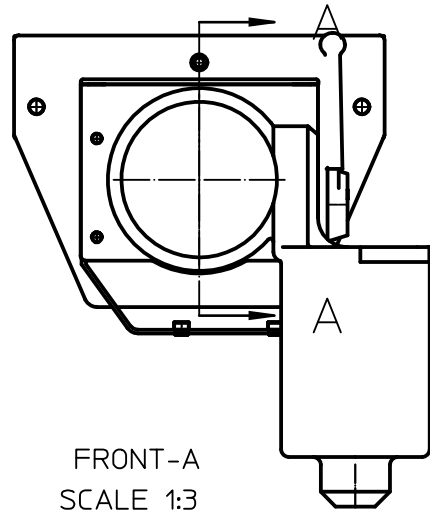

FRONT-A
SCALE 1:3

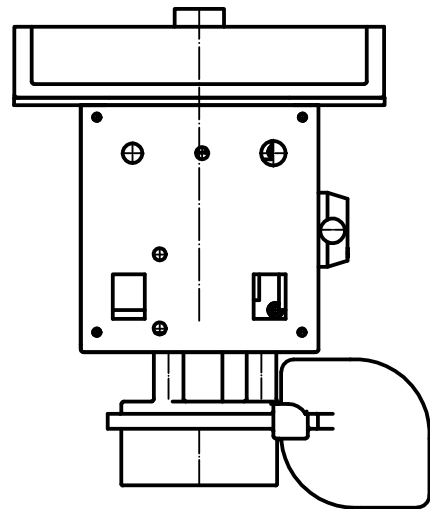

TOP-A
SCALE 1:3

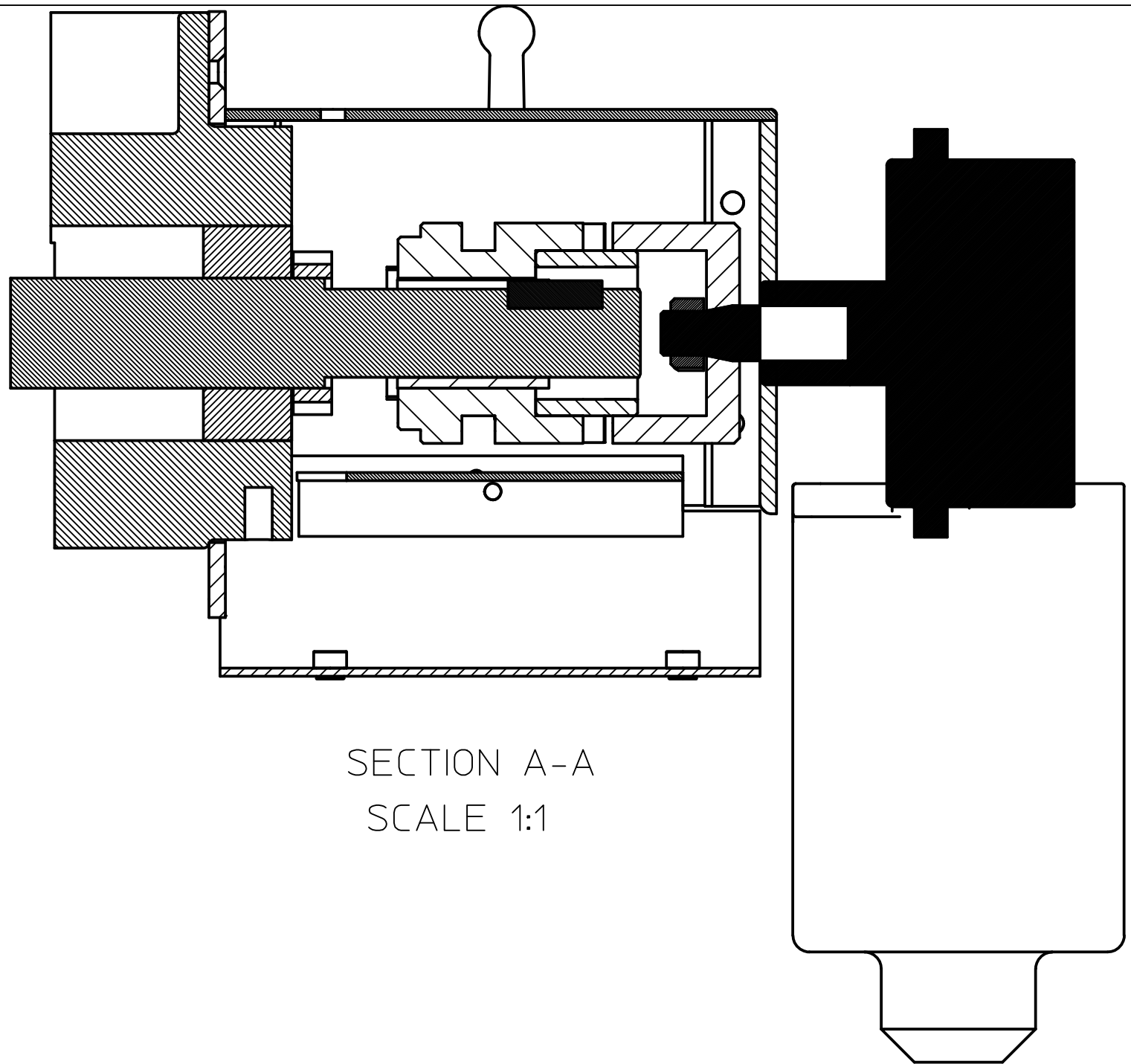

SECTION A-A
SCALE 1:1

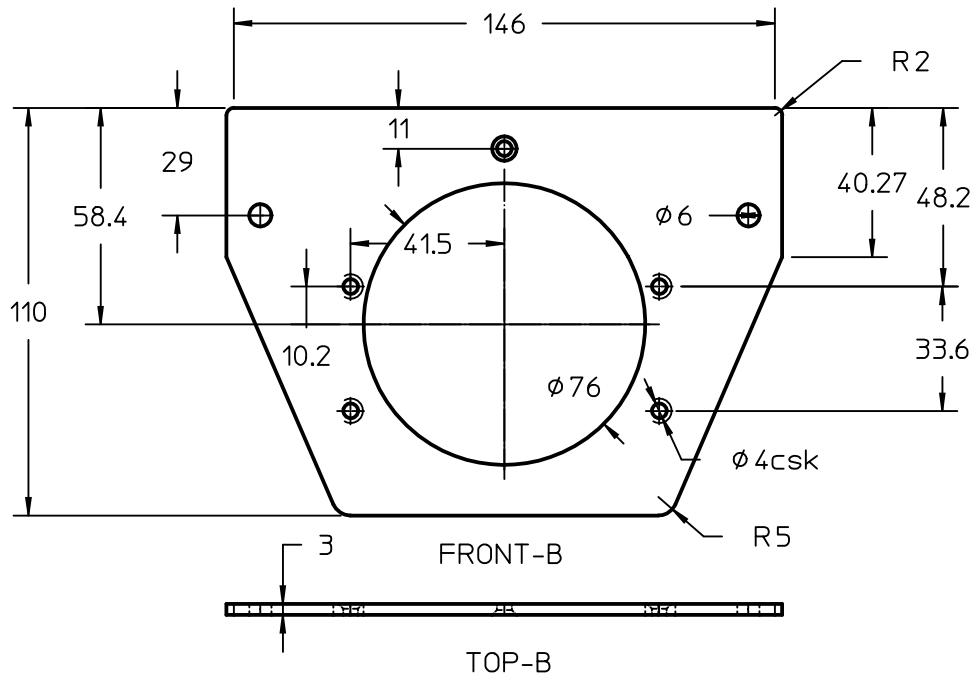

Back Frame

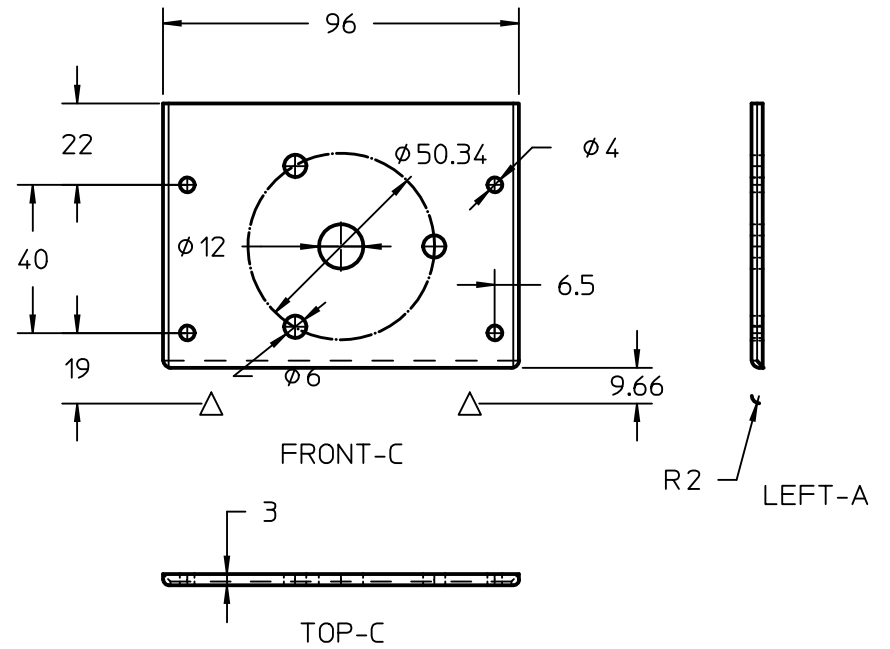

Front Frame

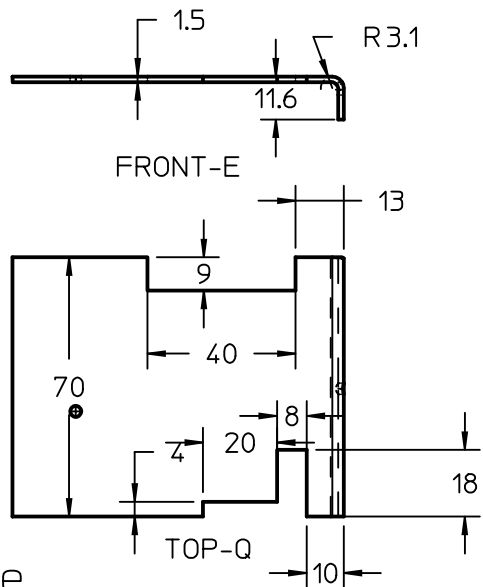

Mid Frame

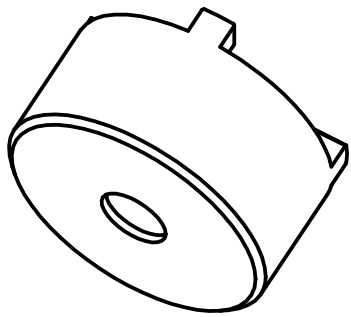

ISOA

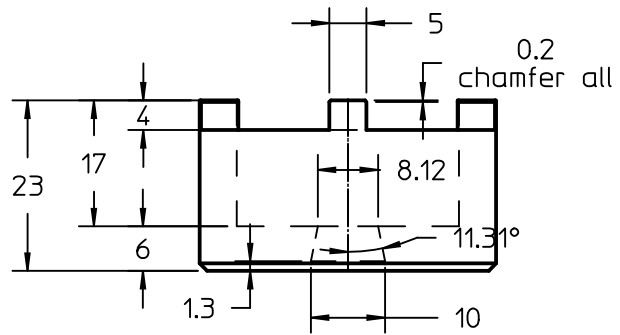
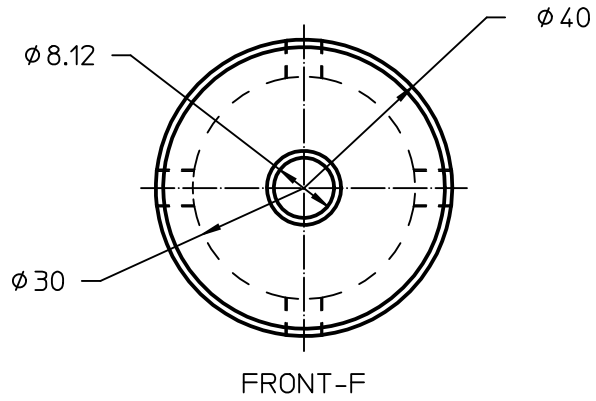

Drive Plate

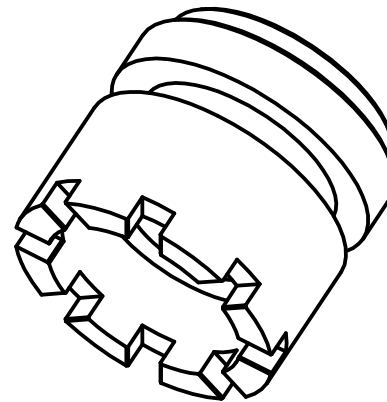

ISOB

Clutch

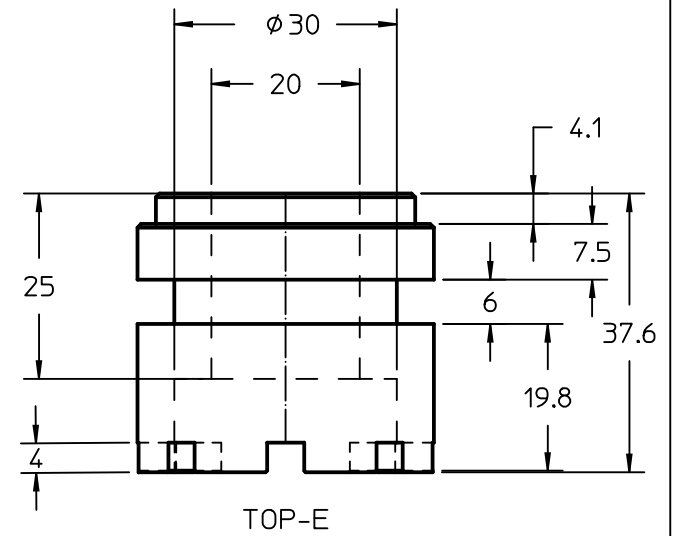
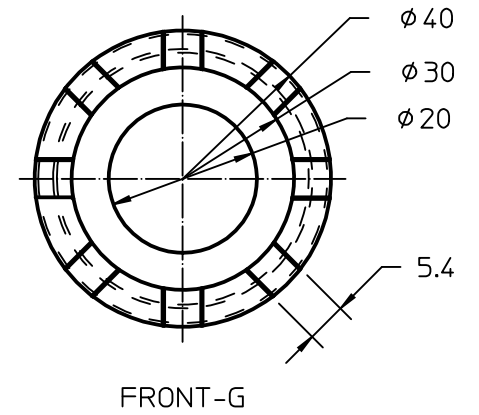

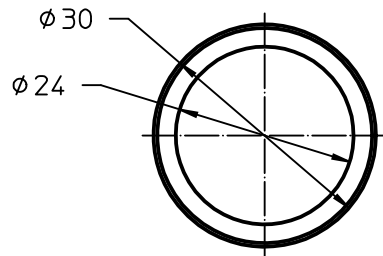

FRONT-H

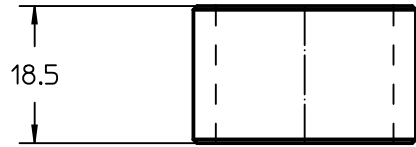

TOP-F

Register Shaft

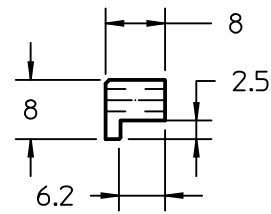

FRONT-K

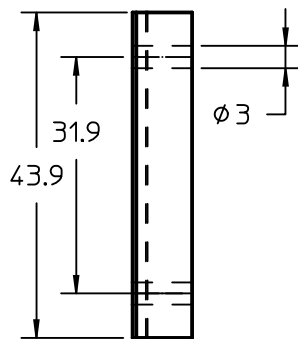

TOP-I

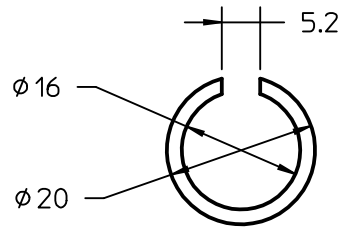

FRONT-J



TOP-H

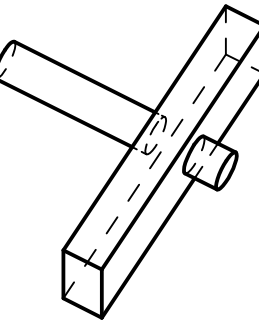

ISOC

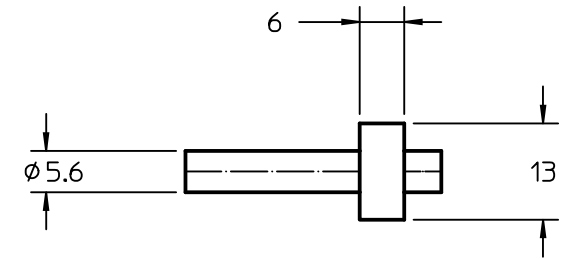

FRONT-I

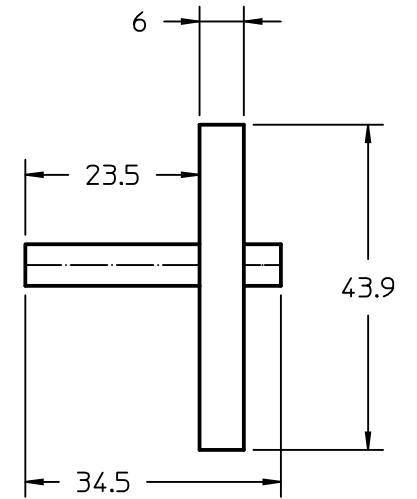

TOP-G

Clutch Actuating Lever

Guides x 2

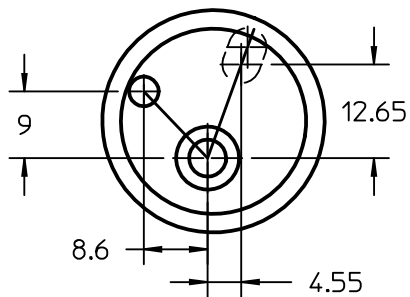
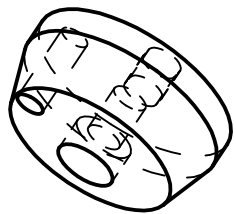

FRONT-L

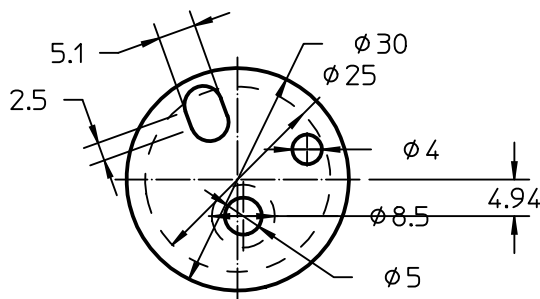

BACK-A

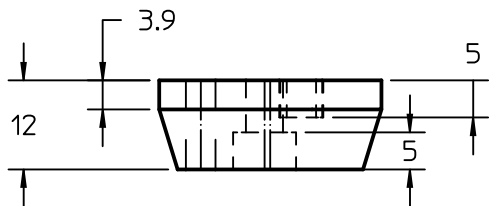

TOP-J

Handle Base

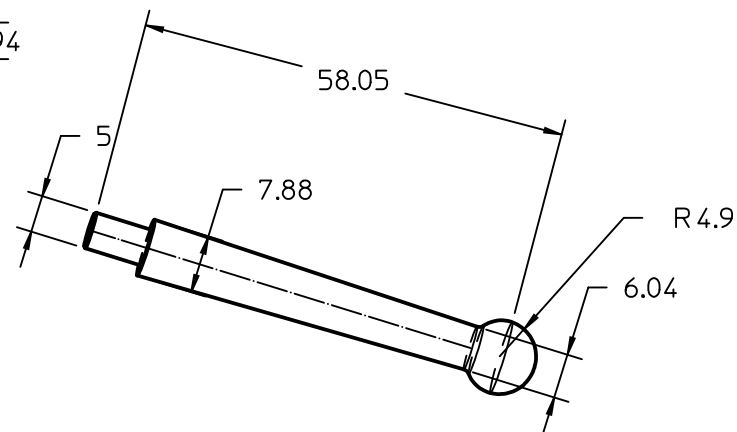

TOP-K

Handle

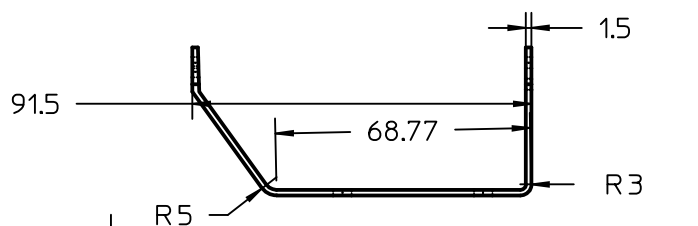

FRONT-U
SCALE 1:2

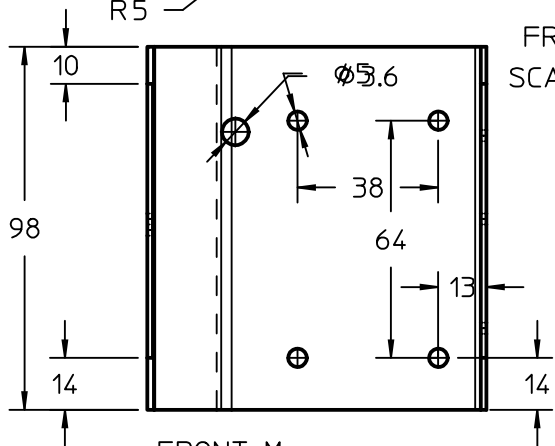

FRONT-M

Bottom Cover

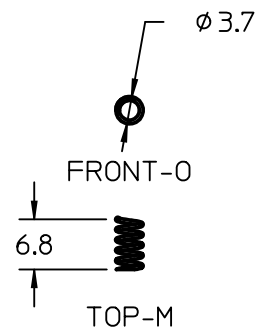

FRONT-O

TOP-M

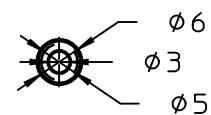

TOP-T

FRONT-V

Stands x4

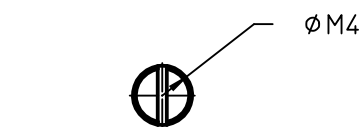

FRONT-N
SCALE 2:1

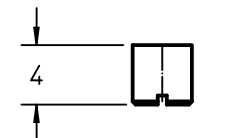

TOP-L
SCALE 2:1

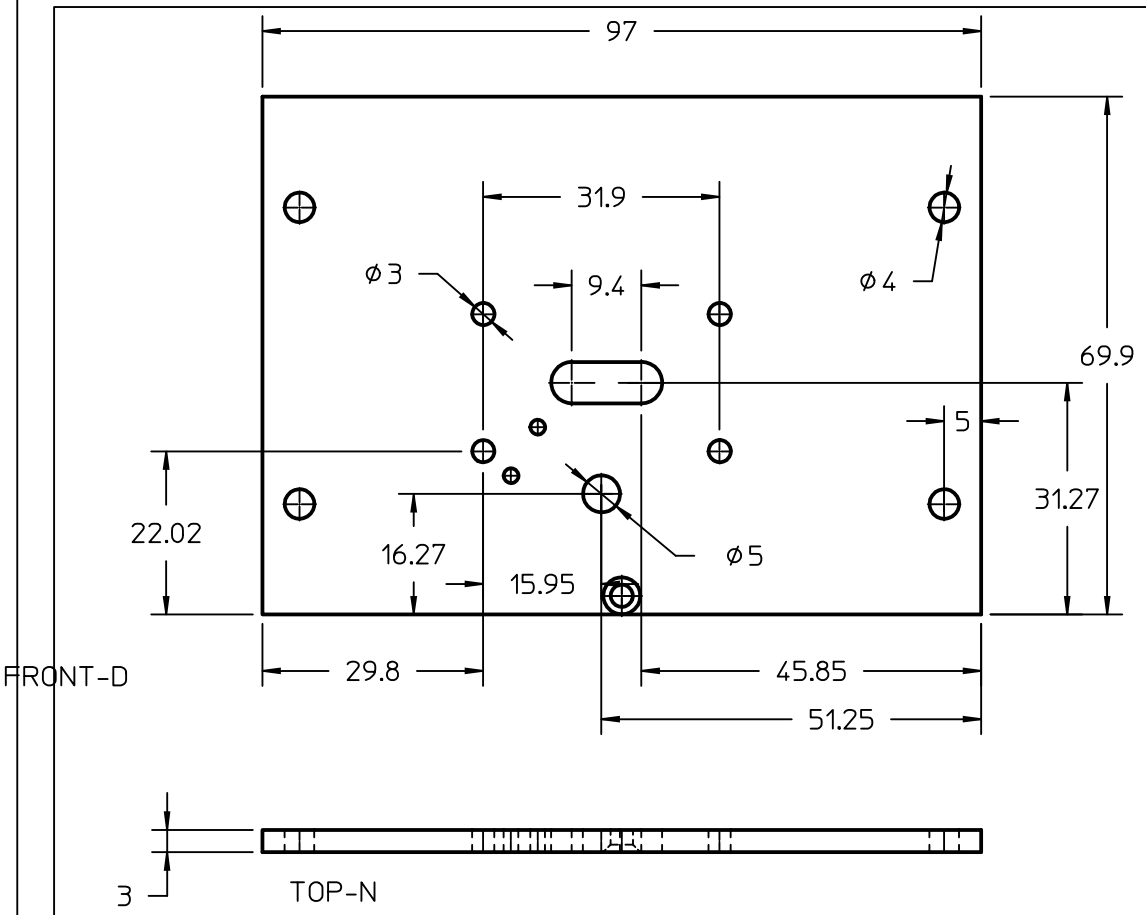

Front Side Frame

FRONT-Q
SCALE 1:2

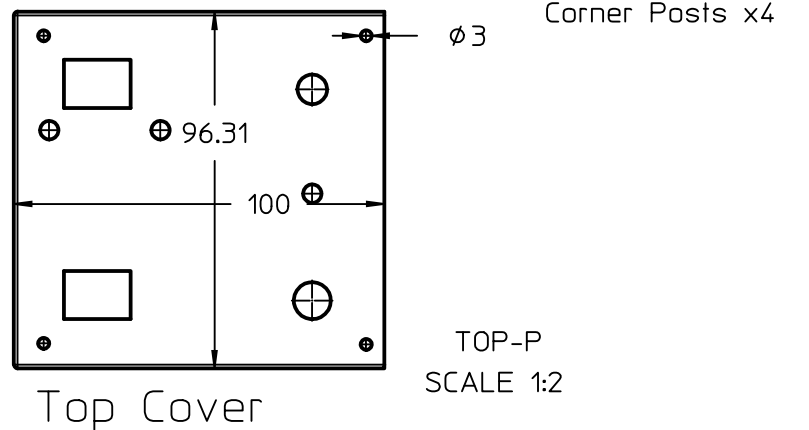
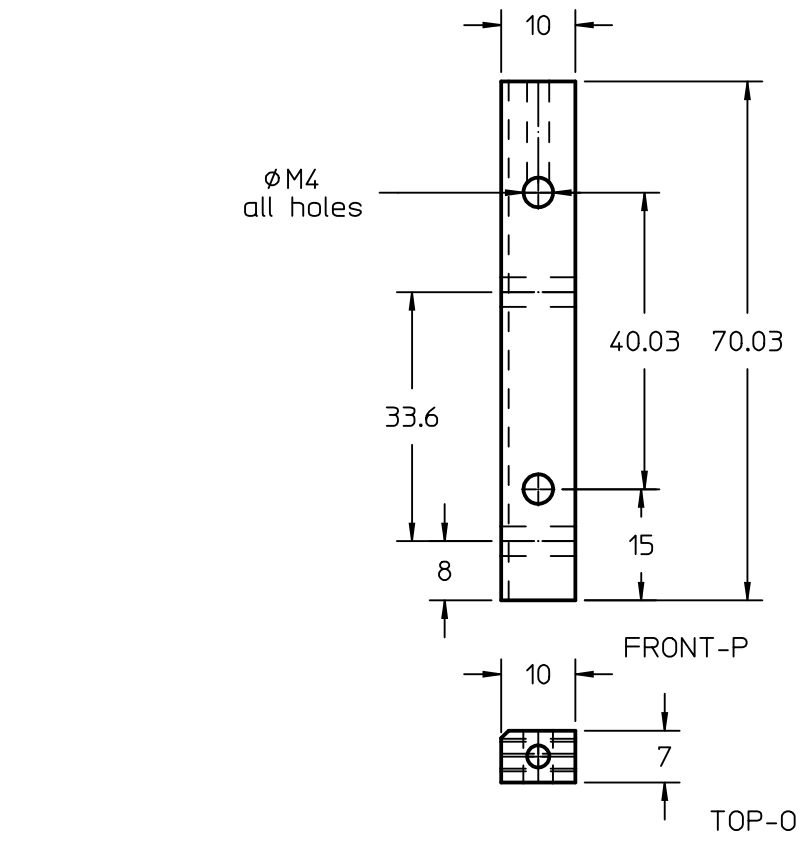

Top Cover

TOP-P
SCALE 1:2

Supply



PWR LED

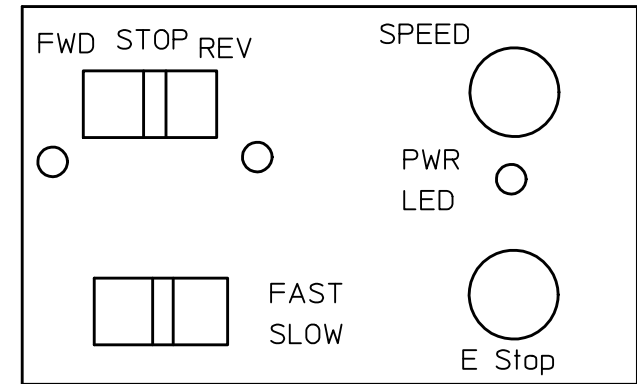

FORWARD/
REVERSE
SW

SPEED
CTRL

POWER CONTROL

DIR. LEDS

E Stop
SW

FAST/
SLOW
SW

MOTOR